

This drawing is the sole property of Miether Bearing Products and contains confidential and proprietary information. It is being provided to you for your use and may not be disclosed to any third party or used for any other purpose without Miether's prior written consent. The [materials] must be returned to the Company upon its demand. Your acceptance of these materials constitutes your acceptance of the foregoing terms.

C-35221

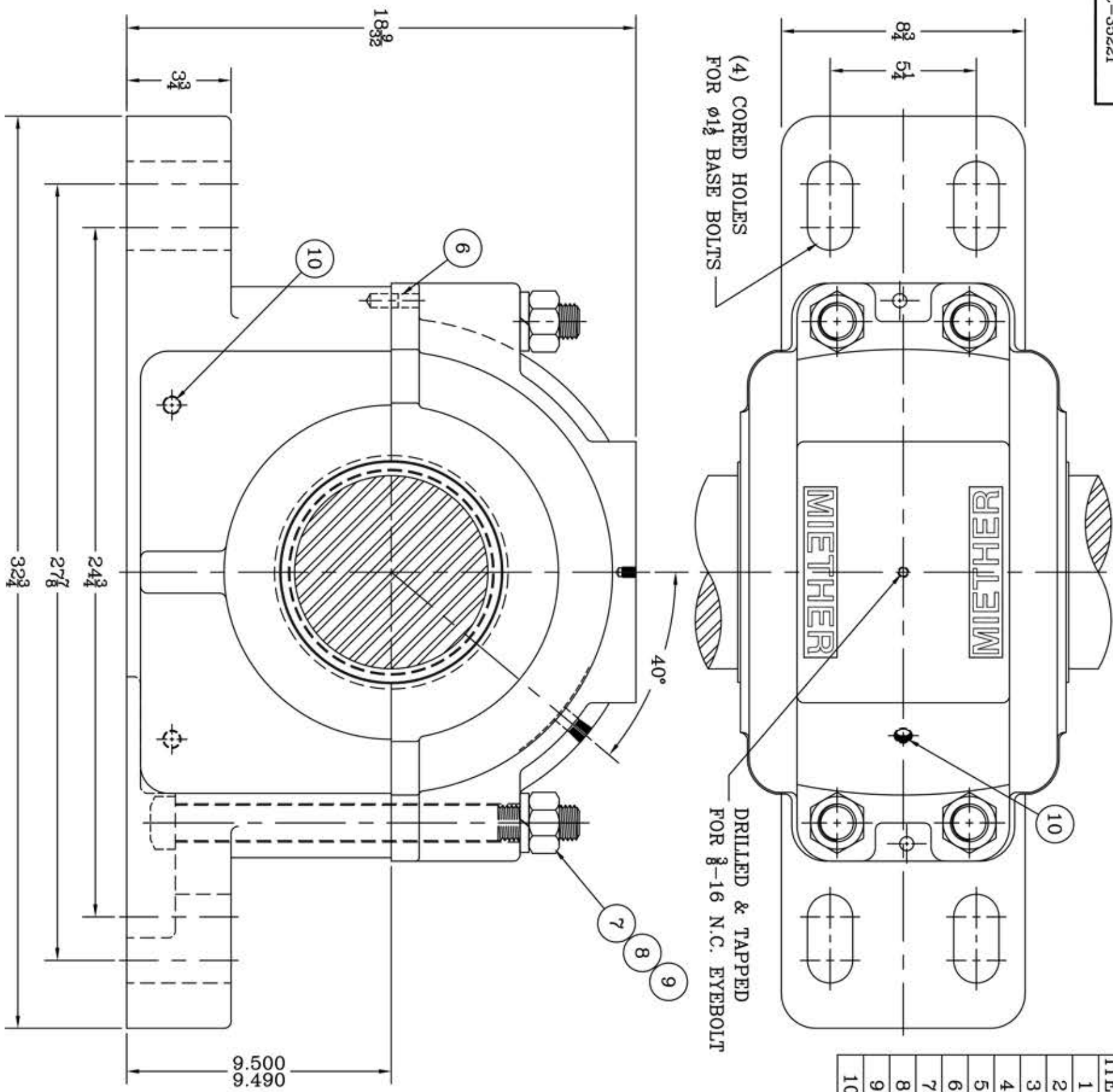

ITEM	DESCRIPTION	DETAIL	REQUIRED
1	HOUSING SAFD 638 06-15	C-	1 1
2	SPHERICAL ROLLER BEARING	22338K/W-33	1 1
3	STABILIZING RING SR-44-38	A-11612	1 0
4	ADAPTER SNW-138 06-15	24476	1 1
5	TRIPLE SEAL RING LER-155	A-10554	2 2
6	DOWEL	Ø 1/2 x 1" LONG	2 2
7	CAP BOLT SQUARE HEAD GR.5	1 1/4-7 NC x 13 3/8 LONG	4 4
8	CAP BOLT HEX. NUT	1 1/4-7 NC	4 4
9	LOCKWASHER	1 1/4 SPLIT MED.	4 4
10	PIPE PLUG	3/8-18 NPT	3 3

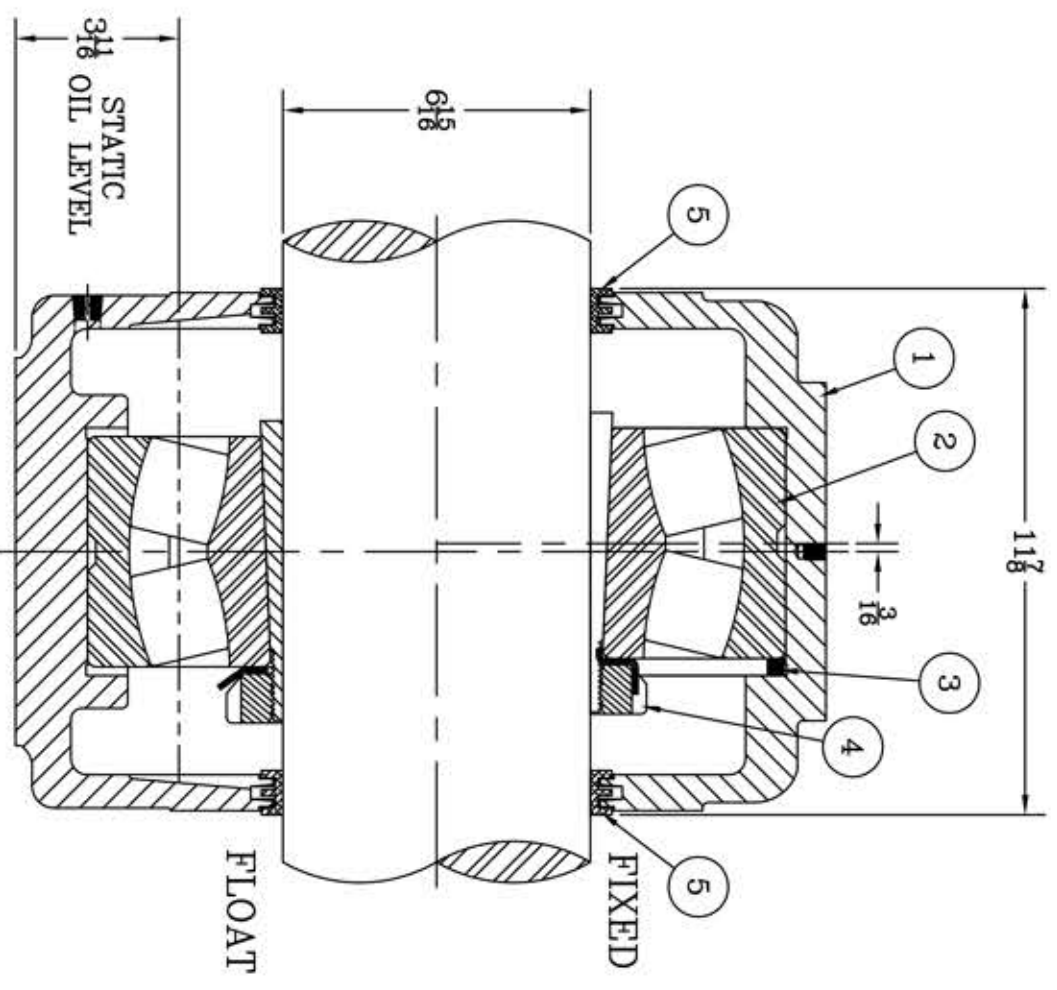

REVISIONS

SYMBOL	DESCRIPTION	MICRO-INCH VALUE
C	...	16
D	...	32
E	...	63
F	...	125
G	...	250
J	...	500
K	...	1000

TOLERANCE: UNLESS OTHERWISE SPECIFIED
 FRACTIONS $\pm 1/32"$ ANGLES $\pm 0^\circ 30'$
 DECIMALS $\pm .005$ WELD $\pm 1/16"$
 CASTING $\pm 1/16"$

A.I.S.I. STANDARD FINISHES

AN ALCO INDUSTRIES COMPANY
 BEARING PRODUCTS
 ODESSA, TX. USA

SAFD 22638 06-15
 ASSEMBLY DRAWING

SCALE 1 = 3
 DRAWN PCF
 DATE 1/2/13
 CHK:

ASSEMBLY NO.
 DRAWING NO.
 C-35221